



NETernity™ CP982RC

PICMG 2.16 6U CompactPCI® 24-Port Managed Layer-2 Gigabit Ethernet Switch with OpenWare™ Lite Switch Management Environment

Features

- 6U CompactPCI® form factor
- 24-port Gigabit Ethernet switch
- Managed Layer-2 solution
- Control and monitoring capabilities via local or remote access
- On-board management processor
- L-2 switching at wire-speed
- OpenWare™ Lite Switch Management Environment
- Supports high availability Hot Swap
- 24 ports routed to the rear, or 22 ports routed to the rear and 2 ports routed to the front
- Rear I/O ports are 10BaseT, 100BaseTX, and 1000BaseT (copper media)
- Front ports can be 10BaseT, 100BaseTX, and 1000BaseT, 1000BaseLX, or 1000BaseSX
- Front panel status LEDs and hardware reset switch
- Polyurethane or acrylic conformal coating optional

Key Specifications

- IEEE 802.3-2005
- PICMG 2.1 (Hot Swappable)
- PICMG 2.16 (Ethernet on the backplane)
- PICMG 2.9 (IPMI compliance)
- IEEE 802.1Q (VLAN tagging)
- IEEE 802.1D (Spanning Tree Protocol)
- RoHS 2002/95/EC compliant

NETernity™ CP982RC is a 24-port Managed Layer-2 Ethernet embedded switch offering full L2 wire speed switching and routing, and control and monitoring capabilities.

Designed to meet the needs of a wide range of applications such as networked Telecom systems, the 6U CompactPCI form factor CP982RC facilitates communications within a chassis as well as supporting the network outside the chassis. It is PICMG 2.16 and RoHS compliant, and supports high-availability hot swap as well as IPMI v1.5.

The CP982RC has 24 10BaseT, 100BaseTX, and 1000BaseT (copper) ports routed to rear I/O. Versions of the switch are also available with 22 10BaseT, 100BaseTX, and 1000BaseT ports routed to the rear and two Gigabit Ethernet ports routed through the front panel. The front accessible interfaces may be 10BaseT, 100BaseTX, and 1000BaseT, 1000BaseSX or 1000BaseLX. Conformal coating is optional.

Switch Fabric Features

- Supports Layer-2 (L2) packet switching. Packets are categorized by the MAC address.
- Virtual LANs (VLANs) (IEEE 802.1Q) defines a forwarding (switching) domain; supports up to 4094 VLANs.
- Multiple Spanning Tree Protocol (MSTP) (IEEE 802.1D-2004) enables automatic and rapid determination of an optimal loop-free topology from an arbitrary network of enabled switches with duplicate and redundant connections; supports rapid reconfiguration in the event of a link or switch failure; backward compatible with RSTP and STP.
- High-availability Hot Swap that complies with PICMG 2.1 Rev 2; the switch may be removed and replaced while the system is operational.
- Port mirroring eases debug and packet pattern study. This is a method to observe on one port traffic that is flowing on another port
- Trunking or manual link aggregation
- SNMP support

OpenWare™ Lite Switch Management Environment

OpenWare™ Lite is available exclusively on selected NETernity Managed Layer-2 Ethernet switches. Configuration and monitoring functions are accessible from a serial console or via a network. Supported access methods include Telnet, SSH and SNMP.

OpenWare Lite features:

- Easy deployment
- Linux® based software allows faster implementation and easy updates to firmware.
- A familiar Linux command line interface and remote Telnet user interface support allows users to select how they interact with the switch.
- Portability across switch fabrics and processor environments.

Why choose GE Fanuc NETernity Ethernet Switches?

GE Fanuc has a wealth of expertise in Military, Commercial and Telecommunications markets. This makes us unique in the embedded computing industry – we understand application requirements and we know communication protocols.

Our line of NETernity Ethernet Switches is unmatched. Not only is our product selection extensive, but the switches themselves provide maximum flexibility, performance, and density.

NETernity Ethernet Switches are available in a variety of form factors, interfaces, levels of ruggedness, port configurations, media support, and types of management.

Fully Managed switches are Layer-2/3+ switches with control and monitoring capabilities via local or remote access. Managed switches are Layer-2 switches with control and monitoring capabilities via local or remote access. Unmanaged switches are Layer-2 switches with no operator interfacing and are designed for quick deployment in well defined applications.

Call GE Fanuc Intelligent Platforms' knowledgeable sales team for help in selecting the switch that best meets your applications requirements.



NETernity™ CP982RC 24-Port Configuration Managed Gigabit Ethernet Switch

Specifications

Physical Interface

- 24 10BaseT, 100BaseTX, and 1000BaseT Gigabit Ethernet ports routed to rear, or 22 10BaseT, 100BaseTX, and 1000BaseT ports routed to rear and 2 front access 10BaseT, 100BaseTX, and 1000BaseT, 1000BaseLX or 1000BaseSX ports
- RJ-45 connectors for rear I/O
Connectors for front I/O: LC (1000BaseLX and 1000BaseSX), RJ-45 (10BaseT, 100BaseTX, and 1000BaseT)

Dimensions

- 6U (4HP) single slot CompactPCI form factor
- Height: 9.2 in. (233.4 mm)
- Depth: 6.3 in. (160 mm)
- Thickness: 0.8 in. (20.3 mm)
- Weight: 1.08 lbs (0.49 Kg)

Power Requirements

- 24 copper ports: 30 W (max)
- 22 copper ports + 2 fiber ports: 32 W (max)

Environmental

- Operating Temperature: 0° to +65 °C
- Storage Temperature: -40° to +85 °C
- Relative Humidity: 5% to 95%, noncondensing

MTBF

- 306,986 hours per FITS

Regulatory Compliance

- European Union (CE Mark)
 - EN55022 Radiated Emissions Class A
 - EN55022 Conducted Emissions Class A
- United States
 - FCC 47 Part 15, Class A
- Safety:
 - UL60950-1
 - CSA C22.2, No. 60950-1
 - EN60950-1 (Low Voltage)
- RoHS 6/6: European Community Directive 2002/95/EC

Block Diagram

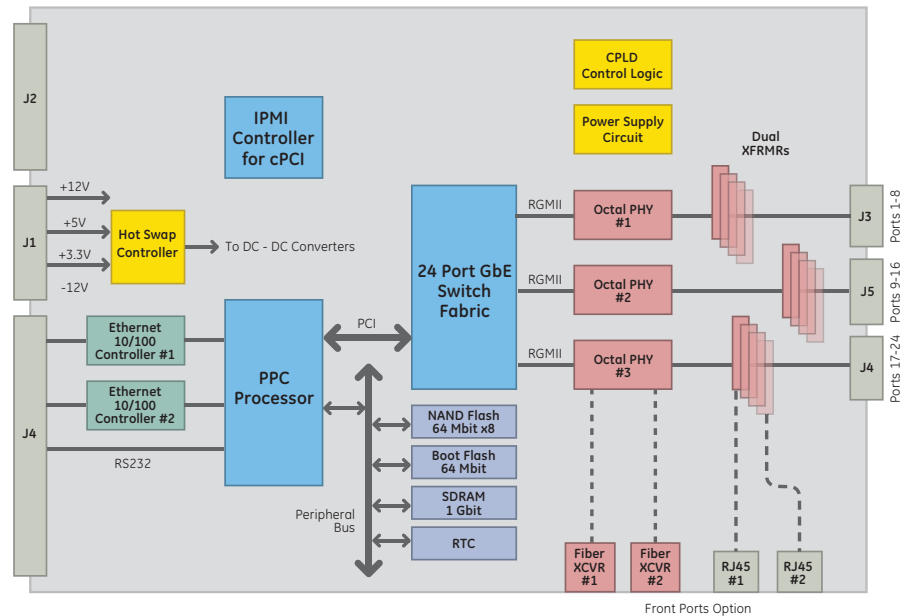

Ordering Information

- CP982RC-200:** NETernity Managed Layer-2 Ethernet switch; 24 rear I/O 10BaseT, 100BaseTX, and 1000BaseT Gigabit Ethernet copper ports; RoHS
- CP982RC-201:** NETernity Managed Layer-2 Ethernet switch; 22 rear I/O 10BaseT, 100BaseTX, and 1000BaseT Gigabit Ethernet copper ports and 2 1000BaseSX front I/O ports; RoHS
- CP982RC-202:** NETernity Managed Layer-2 Ethernet switch; 22 rear I/O 10BaseT, 100BaseTX, and 1000BaseT Gigabit Ethernet copper ports and 2 1000BaseLX front I/O ports; RoHS
- CP982RC-203:** NETernity Managed Layer-2 Ethernet switch; 22 rear I/O 10BaseT, 100BaseTX, and 1000BaseT Gigabit Ethernet copper ports and 2 10BaseT, 100BaseTX, and 1000BaseT front I/O ports; RoHS
- TRCP9XX-5RC:** 5-port rear transition module
- TRCP9XXRC:** 24-port rear transition module
- TRCP9XXRC-12:** 12-port rear transition module

For Conformal Coating, add -CC at end of part number for polyurethane or -CCA for acrylic.

About GE Fanuc Intelligent Platforms

GE Fanuc Intelligent Platforms is a leading global provider of embedded computing solutions for a wide range of industries and applications. Our comprehensive product offering includes many types of I/O, single board computers, high performance signal processors, fully integrated, rugged systems including flat panel displays, plus high speed networking and communications products. The company is headquartered in the U.S. and has design, manufacturing and support offices throughout the world. Whether you're looking for one of our standard products or a fully custom solution, GE Fanuc Intelligent Platforms has the breadth, experience and 24/7 support to deliver what you need. For more information, visit www.gefanuc.com.

GE Fanuc Intelligent Platforms Information Centers

Americas:
1 800 322 3616 or 1 256 880 0444

Asia Pacific:
+81 3 5544 3973

EMEA:
Germany: +49 821 5034-0
UK: + 44 1327 359444

Additional Resources

For more information, please visit the GE Fanuc Intelligent Platforms web site at:

www.gefanuc.com

