

# VP11

## 6U VME64 SBC with Dual Core 32- or 64-bit Processor

### Features

- Intel® Core™2 Duo processor LV, 1.5 GHz
- Intel Core Duo processor 1.66 GHz and 2.0 GHz
- Ultra compact, two slots
- Extensive software support
- Up to 4 GB DDR2 SDRAM (200MHz) with ECC
- Flash Drive or local UDMA2 (ATA33) 2.5" hard disk
- 2x SATA, RAID 0/1 capable
- Front/rear VGA up to 1280x1024, rear DVI-I up to 1280 x 1024, 32 MB RAM
- Two Gigabit Ethernet ports 10/100/1000 BaseT front or rear optional
- Compliant to VITA31.1-2003
- One front Fast Ethernet port
- Two PMC extension slots, one 64-bit/133 MHz and one 32-bit/33 MHz
- One XMC interface on request
- 2 x serial I/O with FIFOs RS-232/422/485 interface
- 4x USB 2.0 ports, two front and two on rear
- Audio codec
- Watchdog, temperature sensors
- Optional -40 °C to +75 °C
- Optional conformal coating
- Customer specific, low cost assembly versions
- RoHS compliant

The VP11 is a 6U VME64 CPU board with integrated dual core Intel Core 2 Duo Processor or Intel Core Duo Processor and dual Gigabit Ethernet channels. The Intel dual core processor includes two optimized execution cores in a single processor case. This enables execution of parallel threads or applications on separate cores with dedicated CPU resources. The VP11 supports a 32- and 64-bit processor architecture. The VP11 is designed to meet the requirements of markets like the automation, simulation/training, test and measurement, and others.

Based on the Intel Core Duo Processor, the platform is designed to support processor speed from 1.66 GHz up to 2.0 GHz. The Intel Core 2 Duo runs at 1.5 GHz. VP11 is offered in a dual slot wide front panel in order to maximize front I/O functions.

The VP11 provides a unique feature set, including up to 4 GB of DDR2 SDRAM (200 MHz) with enhanced ECC, four independent on-board

PCI buses, support for VME64/2eSST backplane, two PMC interfaces (64-bit/133 MHz and 32-bit/33 MHz). Instead of the PMC1 a PCI Express based XMC interface is optionally available. A high level of functional integration (two Gigabit Ethernet, one Fast Ethernet, two serial interfaces (RS-232 or RS-422/485), USB 2.0, integrated HDD or Flash drive) within a single slot gives users the freedom to use the PMC interfaces for their application specific I/O. The VGA/DVI interface is supported through a high performance 2D/3D ATI® video controller capable of driving two displays in parallel.

Versions with front panel I/O are available in various configurations with one or two PMC interfaces. The PMC1 interface can be ordered as a XMC interface instead.

Supported operating systems are Windows®, Linux®, VxWorks® and Solaris. Integrity is available on request.

# VP11 6U VME64 SBC with Dual Core 32- or 64-bit Processor

## Specifications

### VME64, 2eSST - Tundra TSI148

- Industry standard PCI to VME bus controller
- Full VME bus system controller
- FIFOs for write posting, DMA controller with linked list support
- Geographical addressing

#### Protocols supported:

- A16, A24, A32, and A64 address modes
- D8, D16, D32 Single Cycle Transaction (SCT)
- D8, D16, D32 Block Transaction (BLT)
- D64 Multiple Block Transaction (MBLT)
- D64 2eVME, D64 2eSST
- As VME Master Read-Modify-Write (RMW) generation, and RETRY\* as a termination from the external VMEbus slave.

#### Protocols not supported:

- A40, D32 MBLT, VMEbus lock commands
- As slave RMW cycles are not guaranteed indivisible on the PCI bus

### Processor - $\mu$ FCBGA, Low Power Design

- Scalable processing power with flexible processor design
- Supports 32-bit and 64-bit processor architecture
- 64-bit: Intel Core2 Duo processor: 1.5 GHz
- 32-bit: Intel Core Duo processor: 1.66 GHz and 2.0 GHz
- High efficiency on-board switching regulator (DC/DC)
- Fanless cooling with heat sink
- \* Contact factory for latest CPU versions

Processor	Level 2 Cache
Core 2 Duo	4 MB
Core Duo	2 MB

### Chipset - Intel E7520/6300ESB

- 667 MHz front side bus to processor
- Four parallel PCI Express connections to major components for maximum I/O throughput

### Memory - DDR2-400

- High-speed registered DDR2 SDRAM with 400 MHz
- 144-bit wide with enhanced error correction (ECC)
- 32-bit CPU: up to 2 GB soldered memory
- 64-bit CPU: up to 4 GB soldered memory

### Dual Gigabit Ethernet - Intel 82571EB

- Dual Channel Ethernet Controller with PCI Express x4 interface
- 10/100/1000BaseT auto-negotiation
- Front and rear I/O
- Compliant to VITA31.1-2003

### Fast Ethernet - Intel 82551

- Single channel Ethernet Controller
- 10/100BaseT auto-negotiation
- Front I/O

### Hard Disk or Flash Drive

- Internal 2.5" UDMA100 IDE hard disk or Flash Drive for extended temperature range and higher shock/vibration immunity)

### Serial I/O - RS232/422/485

- Two async. 16550 compatible full duplex serial channels at rear I/O
- High-speed transfer up to 115.2 Kbaud with 16 byte FIFOs
- User selectable RS232/422/485 interface
- COM1 optionally available at front

### PMC Extension Slots - IEEE P1386/1386.1

- PMC1 (64-bit/133 MHz) and PMC2 (32-bit/33 MHz), XMC optional on PMC1
- Enhancement to processor PMC standard VITA 32-2003 (non-monarch)
- PMC1 signaling is 3.3 V only, PMC2 signaling is 5 V tolerant.

### VGA and DVI - ATI® X300™

- 256-bit 3D and 2D graphics accelerator
- On-chip up to 32 MB frame buffer
- PCI Express x4 interface
- Dual CRT/Simultaneous Dual Display (same or different surfaces)
- Integrated 400 MHz Palette DAC for analog VGA monitors up to 1280 x 1024
- Single channel DVI-I interface PanelLink® for TFT displays up to 1280 x 1024 true color (EDID displays PnP supported)
- Fully compliant support for OpenGL for all Windows operating systems and Linux
- Versions with front or rear I/O available

### EIDE - 6300ESB

- Ultra ATA/100 sync. DMA mode up to 100 MB/s
- PIO mode 4 and bus master IDE up to 16 MB/s
- One device via on board connector and one via rear I/O

### General Purpose I/O

- 8 GPIO (input or output) pins. Pins are shared with DVI-I.
- Software configurable

### USB 2.0 - 6300ESB

- Two USB 2.0 channels on rear I/O
- Two USB 2.0 channels on front

### Keyboard, Mouse

- Via USB
- Legacy PS/2 controller emulation

### Real-time clock

- RTC 146818 compatible
- Li-battery

### CMOS RAM

- 242 bytes non-volatile CMOS RAM for BIOS use

### EEPROM

- 512 Kbit serial EEPROMs for non-volatile user data

### Floppy

- Via USB

### Watchdog

- Intel TCO timer
- Intel 6300ESB watchdog

### Timer

- Integrated in 6300ESB chipset
- Legacy PC-AT timer
- High Precision Event Timer (HPET)

### Temperature Sensors

- CPU die, Intel E7520 and pcb temperature software readable in the range of -55 °C to +125 °C

### LED (not in conduction-cooled style)

- Front panel ACPI System Status Indicator LED (red/amber/green)

### Audio

- Line In, CD In
- Headphone, SPDIF Out
- AC97 link with codec
- 0 °C to +70 °C only (tbd)

# VP11 6U VME64 SBC with Dual Core 32- or 64-bit Processor

## BIOS Features

- AMI BIOS Core 8, in-system programmable Flash ROM
- Automatic system configuration
- Integrated VGA, SATA RAID and Ethernet PXE ROM
- USB Mass Storage support
- Password protection
- Headless support
- Remote console through serial port

## Software

- The following software is supported to the extent listed below.

OS	On Request	Planned
Windows		√
Linux		√
VxWorks		√
Integrity	√	

## Front and Rear I/O (with transition module VTM22)

- The pin outs of the transition module connectors (rear I/O) correspond to standard PC connectors (press-fit cables).

Function	Front	Rear
	Air Cooled	P2/PO
DVI-I	-	√ <sup>1,4</sup>
VGA	√	√ <sup>1</sup>
Gigabit Ethernet 1	√ <sup>2</sup>	√ <sup>2</sup>
Gigabit Ethernet 2	√ <sup>2</sup>	√ <sup>2</sup>
Fast Ethernet	√	-
Reset	√	√
LEDs	√	√
USB 2.0 1-4	1-2	3-4
IDE (ATA100)		√
IDE (ATA33)	onboard <sup>3</sup>	
SATA 1		√
SATA 2		√
COM 1-2	1	1, 2
Audio		√
GPIO (8 pins)	-	√ <sup>4</sup>
PMC 1 (XMC on req.)	√	√
PMC 2 I/O	√	√ <sup>3</sup>

- 1 Rear DVI-I connector for DVI and VGA
- 2 Either front or rear as an order option
- 3 Full PMC 2 rear I/O without IDE primary used  
Partly PMC 2 rear I/O with IDE primary used
- 4 DVI-I (DVI-D pins) are shared with GPIO pins

## Styles

Function	Style 1	Style 3	Style 6	Style 8
Front Panel	yes	yes	yes	no
Parts Soldered	yes	yes	yes	yes
Li-Battery	yes	yes	no	no
Ext. Temperature	no	yes	yes	yes

## Power Requirements

- +5 V, +3.3 V, +12 V Required
- -12 V If required by mounted PMC module

## Power Consumption - typical operating current

- Without keyboard, hard disk, modules, Ethernet (no link), measured at DOS prompt, no power savings.

Processor	5 V	3.3 V	Total Power
Core 2 Duo, 1.5 GHz			
Core Duo, 1.66 GHz			
Core Duo, 2 GHz			

- Without keyboard, hard disk, modules, Windows XP, 3D graphics active. Both Gigabit Ethernet channels linked, CPU running at instruction mix for maximum power consumption.

Processor	5 V	3.3 V	Total Power
Core 2 Duo, 1.5 GHz			
Core Duo, 1.66 GHz			
Core Duo, 2 GHz			

## Power Allowances - PMC slots

- +5 V, +3.3 V: Total power max. 7.5 W
- ±12 V: 100 mA each

## Mechanical - PICMG 2.0

- 6U, 2 slots wide, (233 x 160 x 40) mm with Flash Drive or hard disk

## Temperature

- **Note:** For detailed information about the operating temperature behavior of the board of any style it is absolutely necessary to consult the manual. The processor type and speed, altitude, the use or not use of Ethernet and video, ambient conditions and the type of cooling influences the board temperature range.

## Temperature

Range	Operating		Storage	
	Standard	Extended	Standard	Extended
	0 °C to +55 °C	-40 °C to +75 °C	-40 °C to +85 °C	-40 °C to +85 °C

Humidity	Operating		Storage	
	Standard	Extended	Standard	Extended
	5 - 95 % @ 40 °C	5 - 95 % @ 40 °C	5 - 95 % @ 40 °C	5 - 95 % @ 40 °C

**Altitude** 15,000 ft. (4.5 km) 40,000 ft. (12 km)

## Shock and Vibration

- Designed to meet VITA47 class EAC1 and EAC3

## VITA 47

- Designed to meet VITA47 class EAC1 and EAC3

## MTBF

- Calculations are available in accordance with MIL-HDBK-217. Please contact Ge Fanuc Embedded Systems.

## Safety

- Designed to meet standard UL1950, CE class A, FCC-A

# VP11 6U VME64 SBC with Dual Core 32- or 64-bit Processor

## Block Diagram

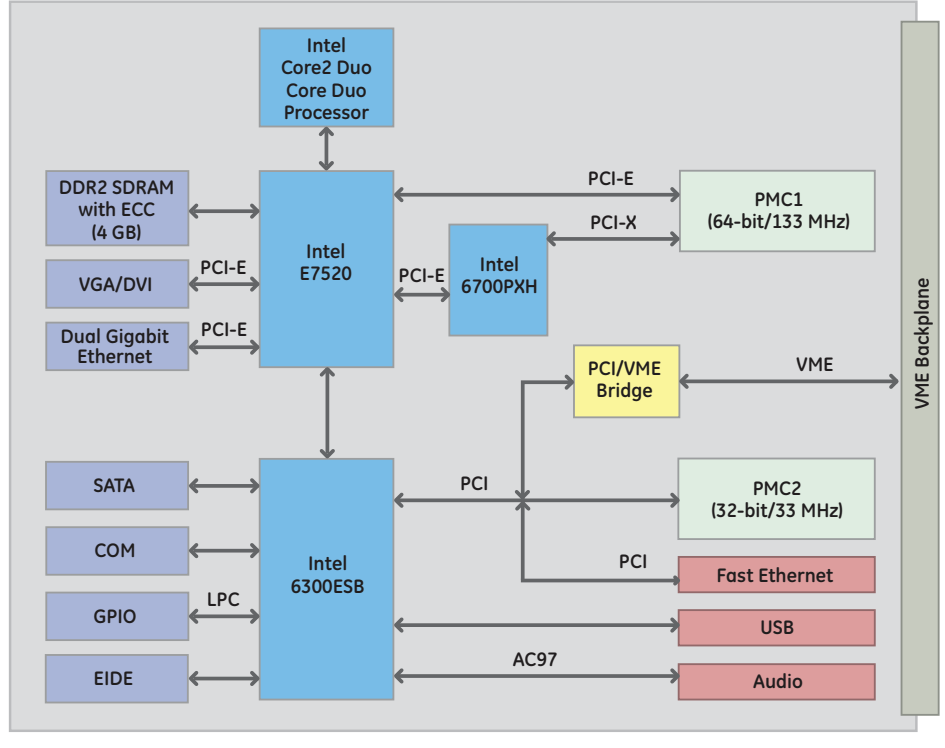

## Ordering Information

### Hardware Accessories

**VTM22:** I/O transition module for 6U backplane (IEEE 1101.11-1998 compliant)

**SCC784UM05VP11R:** 7U, 19" starter cage with 5 VME64 slots, backplane, HDD, DVD, power supply

### Operating Systems

Extensive operating systems support is available, (see page 2 of this document).

Chassis with power supplies, backplanes and drives on request.

For detailed information and further options, contact SBS Technologies.

## About GE Fanuc Embedded Systems

GE Fanuc Embedded Systems is a leading global provider of embedded computing solutions for a wide range of industries and applications. Our comprehensive product offering includes many types of I/O, single board computers, high performance signal processors, fully integrated, rugged systems including flat panel displays, plus high speed networking and communications products. The company is head-quartered in the U.S. and has design, manufacturing and support offices throughout the world. Whether you're looking for one of our standard products or a fully custom solution, GE Fanuc Embedded Systems has the breadth, experience and 24/7 support to deliver what you need. For more information, visit [www.gefanucembedded.com](http://www.gefanucembedded.com).

## GE Fanuc Embedded Systems Information Centers

Americas:  
1 800 322 3616 or 1 256 880 0444

Asia Pacific:  
+81 3 5544 3973

EMEA:  
Germany: +49 821 5034-0  
UK: +44 1327 359444

## Additional Resources

For more information, please visit the GE Fanuc Embedded Systems web site at:

[www.gefanucembedded.com](http://www.gefanucembedded.com)

