

bCOM2-L1100

Rugged COM Express Board

Features

- Compliance to PICMG™ COM Express R1.0 basic form factor, Type 2
- Processors
 - Intel® Core™ 2 processor, soldered
 - Up to 2.26 GHz, 1066 MHz FSB, 6 MB L2, 25 W
- Up to 2 (4) GB DDR3 SDRAM; soldered, non-ECC
- Intel GS45/ICH9M SFF chipset
 - 800/1067 MHz FSB
- I/O Features
 - 1x VGA
 - 2x SDVO channels (shared with PEG)
 - 1x LVDS (dual channel support)
 - 1x Gigabit Ethernet
 - 8x USB 2.0
 - Audio HDA
 - 4x Serial ATA ports (RAID)
 - 1x PATA
 - 8x GPIO (4 in, 4 out)
- Expansion
 - 1x PCIe Graphics (PEG) x16
 - 4x PCIe lanes
- 4x lanes x1 or 1x lanes x4
 - PCI (32-bit / 33 MHz)
- Extended operating temperature range from -40° to +85° C
- Temperature sensors for CPU, chipset and module
- Optional conformal coating
- Support of S0, S3 and S5 states
- Support for Windows® XP, Vista®, Linux®, and VxWorks®
- High shock and vibration immunity
- Pre-mounted heat sink/spreader for optimal cooling

The bCOM2-L1100 is a rugged, Type 2 COM Express module in basic form factor. It features a soldered Intel Core 2 Duo processor with varying levels of performance-per-watt improvements to provide an excellent choice for System Integrators with low-power, high performance embedded applications requirements.

The bCOM2-L1100 offers up to 4 GB of soldered DDR3 SDRAM memory to satisfy an application's needs. One Gigabit Ethernet port is routed to the COM Express connector, located on the baseboard. This port supports transmissions of 10 and 100 Mbit/s. An additional eight USB 2.0 ports are routed to the COM Express connector.

The bCOM2-L1100 has four serial ATA Interfaces with RAID 0 and 1 support. Choose from the parallel-attached hard disk drive or the new serial ATA drive. The SATA interfaces are ready for SATA II drives.

For superior graphic performance, the bCOM2-L1100 features integrated analog CRT and LVDS interfaces along with two SDVO channels.

I/O functionality is provided through either four PCI Express x1 lanes or one x4 lane, a wide PCI Express x16 port, and one 32-bit/33 MHz PCI bus.

The x16 port can be used in applications where high-end graphic and video capabilities are required. Together with the audio port a wide range of multimedia implementations can be achieved.

All of these functions position the bCOM2-L1100 in applications for industrial, simulation/training, test and measurement, gaming, transportation and other market segments. With its soldered components and optional high shock and vibration protection, the module can be placed in harsh environments. Furthermore extended temperature and conformal coating options positions the module for applications in transportation, mining, MIL/Aero, and others.

Evaluation, Benchmarks, Development

The carrier board CCAR-L1000 is available for an easy and quick start, to do benchmarks or even to develop/test application software. The CCAR-L1000 is designed for the COM Express module series. The carrier supports the standard features of the bCOM2-L1100 plus PCI and PCI Express slots. For detailed functions see the CCAR-L1000 datasheet.



bCOM2-L1100 Rugged COM Express Board

Specifications

Processor

- Intel Core 2 Duo processor, soldered
 - SV SP9300, 2.26 GHz, 1066 MHz FSB, 6 MB L2, 25W
 - LV SL9400, 1.86 GHz, 1066 MHz FSB, 6 MB L2, 17W
 - ULV SU9300, 1.2 GHz, 800 MHz FSB, 3 MB L2, 10W

Chipset - Intel

- Intel GS45/ICH9M SFF
- 800/1067 MHz FSB

Memory

- Supports up to 4 GB of DDR3 SDRAM
- Soldered, non-ECC

Graphics Features

- Integrated graphics interface
 - 1x VGA
 - 2x SDVO channels (shared with PEG)
 - 1x LVDS interface (dual channel support)

Audio

- Supports HDA

LAN Port

- 1x Gigabit Ethernet port

Serial ATA Interface

- Supports 4x serial ATA interfaces, compliant with SATA 1.0 specification
- Supports SATA-II devices with speed up to 3 Gb/s
- Supports RAID 0 and RAID 1

IDE Interface

- Supports one PATA

USB Interface

- Supports eight USB 2.0 ports

Others

- States: S0, S1, S2, S3, S4, S5
- Alarm sensors for temperature, chipset

Extension

- 1x PCI Express x16
- 4x PCI Express x1 or 1x PCI Express x4
- PCI (Master), four devices

I/O Interface

- 8x GPIO (4 in, 4 out) ports

Power

- Input: 12V, 5 VSB

Temperature

- Operating: 0° to +60° C (standard)
- Operating: -40° to +85° C (extended)
- Storage: -40° to +125° C

NOTE: Maximum operating temperature range is dependant on the selected processor version

Humidity

- Operating: 10% to 90%

Shock / Vibration

- Level A and F
 - Shock: 20g, 11 ms
 - Vibration: 5 - 100 Hz, 0.04 g²/Hz, 60 minutes per axis
- Level D
 - Shock: 40g, 11 ms
 - Vibration: 5 - 2000 Hz, 0.1 g²/Hz, 60 minutes per axis

Block Diagram

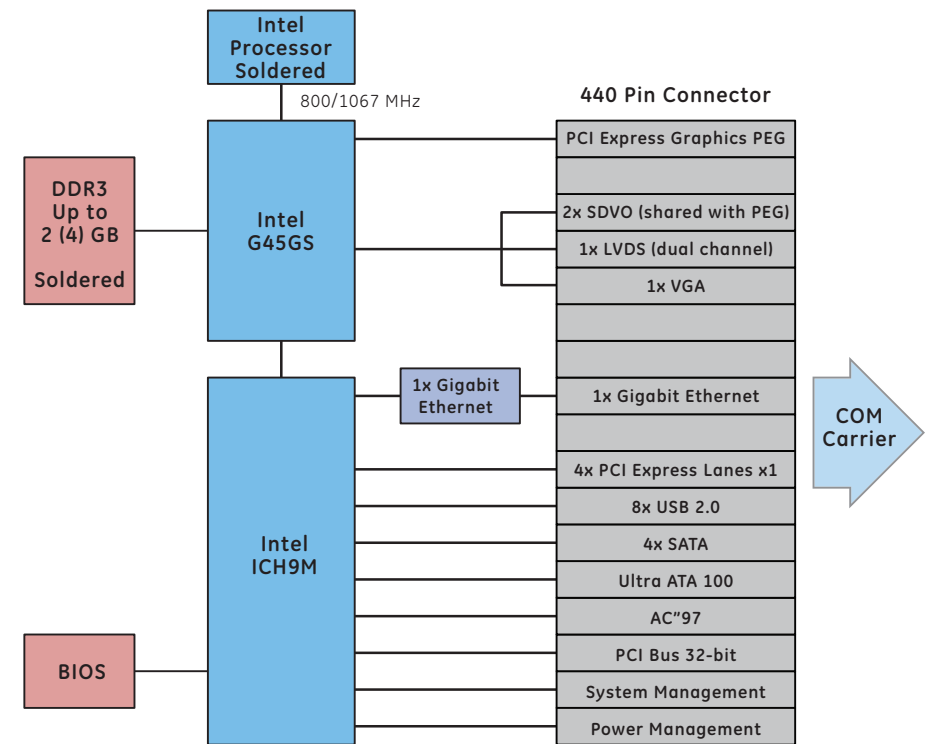

BIOS

- AMI
- SPI interface

PCB

- Dimensions: COM Express basic form factor; 95 mm x 125 mm (3.74" x 4.9")
- Compliance: PICMG COM Express R1.0

Software Support

- Windows XP, Linux, VxWorks

Options

Ruggedization

- Conformal coating
- Shock and vibration protection

Ordering Information

BCOM2L11C5AA Basic COM Express module of type 2 with soldered processor (Intel Core 2 Duo, 1.2 GHz, 3 MB L2 cache), soldered 2 GB DDR3 memory and active heat sink (with fan).

BCOM2L11E5AA Basic COM Express module of type 2 with soldered processor (Intel Core 2 Duo, 2.26 GHz, 6 MB L2 cache), soldered 2 GB DDR3 memory and active heat sink (with fan).

CCARL1000 Standard bCOM2-L1100 COM Express carrier without COM Express module

GE Intelligent Platforms Contact Information

Americas: **1 800 433 2682** or **1 434 978 5100**

Global regional phone numbers are listed by location on our web site at www.ge-ip.com/contact

www.ge-ip.com

