

Titan 3U OpenVPX SATA RAID/JBOD



Industry Standard Small Form Factor Rugged Storage



FEATURES

- 3U OpenVPX
- 1" single / dual slot
- Up to 5x 2.5" Solid State Disks per module (dual slot)
- Up to 2TB SSD Storage
- High performance JBOD configuration
- High reliability hardware RAID configuration
- 3Gbit/s SATA Interface
- 250MB/s sustained read/write performance
- Rugged conduction cooled
- Cost saving air cooled, rotary drive options available for benign / lab environments

APPLICATIONS

- UAVs, UGVs
- Data Recorders
- Medical Imaging
- Surveillance
- DSP Systems

BENEFITS

- Rugged design
- Optimized for Size, Weight and Power (SWaP)
- High storage density
- OS agnostic
- Scalable

Galleon's Titan family of VPX products supports a variety of usage models for integration of solid state storage into 3U OpenVPX systems.

Designed to meet the most demanding environmental conditions, the Titan OpenVPX rugged SATA RAID/JBOD brings reliable mass storage into small rugged applications. Current Solid State Disk technology offers capacities of up to 2TB of storage in a dual slot 3U OpenVPX form factor, making it ideally suited for use in small deployed systems like UAVs and UGVs.

Typical applications include RADAR, SONAR, medical imaging, surveillance, telecom, high resolution video, etc.

The Titan enclosure allows two 2.5" Solid State Disks to be installed in a single 1" VPX slot and up to five SSDs in a dual slot configuration. The SATA host link utilizes a SATA Port Multiplier, which allows a single Serial ATA host port to communicate with multiple drives simultaneously. All drives share the 3Gbit/s physical bandwidth of the SATA host link effectively providing 250MB/s sustained read/write performance.

The Titan RAID/JBOD is fully OS agnostic and no SW or drivers are required. The individual disks are visible to the host OS and can be used with any file system.

RAID applications can be used either for increased performance (RAID 0, 10) and/or increased reliability (RAID 1, 3, 5 and 10).

The compact module design allows easy transporting of the data for secure or archival storage or for transferring data files to operational storage arrays, servers or host platforms.



galleon
embedded computing as

Titan 3U OpenVPX SATA RAID/JBOD

How it works

The Serial ATA port multiplier (SATA PM) allows a single SATA port to communicate with multiple SATA devices. The Port Multiplier used on the Titan SATA RAID/JBOD supports both Command-based and FIS-based switching. FIS-based switching offers high performance storage connections to multiple drives simultaneously, so that all drives can efficiently share the full bandwidth of the SATA host link.

The Titan SATA RAID/JBOD allows your system SBC to see up to five individual SATA drives on a single SATA connection. Most SBCs on the market have one or two SATA ports to the backplane. With the Titan SATA RAID/JBOD, up to five SATA drives can be connected to each physical SATA port. Utilizing the full bandwidth of the interface at 3Gbit/s, this makes it ideal for use as a RAID 1, 3 or 5 storage device for increased data security or in a JBOD, RAID 0 and 10 configuration for increased performance.

Application Example

Using a COTS Single Board Computer and two Titan SATA JBODs, it is possible to build a data recorder with 500MB/s sustained bandwidth and 4TB of solid state storage in a 5-slot 1" pitch 3U OpenVPX system!

Usage Model

The Titan OpenVPX SATA RAID/JBOD provides high-speed storage in a very small enclosure. Combined with a custom storage controller or a COTS SBC, it is ideally suited for streaming storage applications such as:

- Digital Signal Processing (DSP)
- Radar and Sonar
- Satellite Download
- Surveillance
- High Speed Data Acquisition
- High Resolution Video

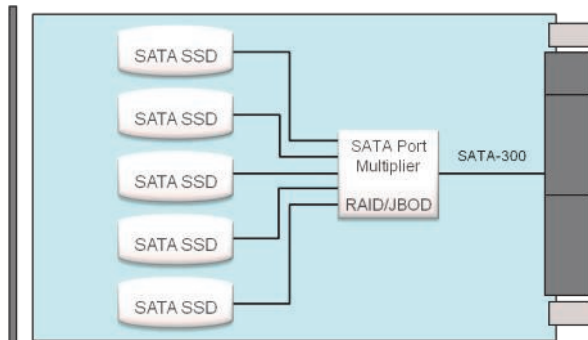

Technical Specification

- Supports up to 5x 2.5" SSD SATA Drives
- SATA-300 3Gbit/s SATA host interface
- JBOD, RAID 0, 1, 10, 3 and 5 supported in HW
- 1" 3U OpenVPX Compliant (single/dual slot)
- Air and Conduction cooled variants available
- -40°C to +85°C Operational temperature (CC)
- -55°C to +95°C Storage temperature (CC)
- Vibration: 5-2000Hz, 20Grms, 3 axes, operational
- Shock: 40G, 11ms, 3 axes
- Humidity: Up to 95%
- Altitude: -1500 to 60 000 ft
- Tested according to MIL-STD-810F

All specifications dependent on qualification with selected storage media.

Ordering Information

Titan VPX3-S2SSD-xyz, single slot version

Titan VPX3-S4SSD-xyz, dual slot version

-xyz denotes environmental level. Contact factory for full specification.

Version 1.5/05.07.2010

All data subject to change without notice. All brand or product names are trademarks or registered trademarks of their respective owners.

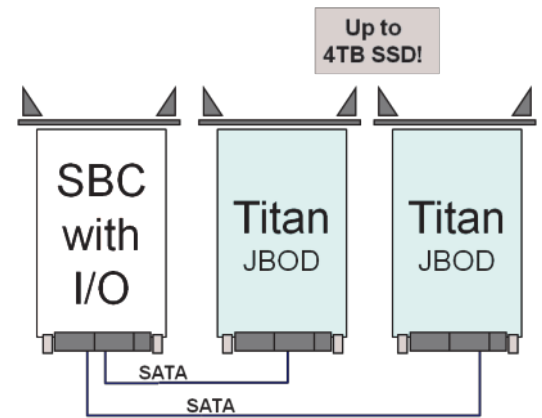

COTS Data Recorder

The Titan SATA RAID/JBOD is the ideal building block for a small rugged data recorder. Supported by most OpenVPX Single Board Computers, the Titan Storage module enables in-house design of high performance rugged recorders with low effort and risk using COTS hardware. Typical applications include recording of HD Video, Ethernet, sFPDP, Sensor data, etc.



The Titan Express RAID/JBOD is available in a single slot version for two SATA drives and a dual slot version for up to 5 SATA drives.

An air cooled variant is available in both single and dual slot configurations, supporting cost optimized rotating drives.



Østensjøveien 44
N-0667 Oslo, Norway

Phone: (+47) 4777 3133

Email: info@galleonembedded.com

Web: www.galleonembedded.com